

Dane techniczne

Typ	prędkość obrotowa [obr./min]	moc silnika [W]	natężenie [A]	napięcie [V]	wydajność max. [m³/h]	ciśnienie max. [Pa]	poziom ciśnienia akustycznego [dB(A)]	masa [kg]	nr artykułu
IBF/2-190	2400	85	0,34	230	600	300	64	7,5	41010010
IBF/2-220	2790	110	0,53	230	900	400	71	12	41010020
IBF/2-280	1850	260	1,1	230	1500	540	76	16	41010030
IBF/4-280	1400	90	0,4	230	1000	150	61	15,5	41010040
IBF/4-315S	1440	120	0,56	230	1400	230	66	22	41010050
IBF/4-355S	1400	230	1,16	230	2250	270	68	33	41010060
IBF/6-315S	965	47	0,18	230	1050	120	51	22	41010070
IBF/6-355S	875	66	1,16	230	1700	140	55	33	41010080
IBF/4-315T	1400	120	0,48	400	1400	230	66	22	41010090
IBF/4-355T	1400	230	1,1	400	2250	270	68	33	41010100
IBF/4-400S	1355	520	2,2	230	4050	380	78	35	41010110
IBF/4-400T	1345	460	0,85	400	4050	380	78	35	41010120
IBF/6-400S	880	160	1,6	230	2750	170	67	35	41010130
IBF/6-400T	890	160	0,36	400	2750	170	67	35	41010140
IBF/4-450S	1280	740	3,2	230	5500	440	83	85	41010150
IBF/4-450T	1230	690	1,3	400	5500	440	83	85	41010160
IBF/6-450S	840	240	1,05	230	3800	210	74	85	41010170
IBF/6-450T	880	250	0,6	400	3800	210	74	85	41010180
IBF/4-500S	1320	1300	4,7	230	7800	600	83	122	41010190
IBF/4-500T	1320	1200	2,2	400	7800	600	83	117	41010200
IBF/6-500S	820	380	1,65	230	5150	250	73	110	41010210
IBF/6-500T	850	390	0,81	400	5150	250	73	110	41010220
IBF/4-560T	1230	1800	3,41	400	10200	690	88	155	41010250
IBF/6-560S	810	670	3	230	7500	300	78	155	41010260
IBF/6-560T	850	690	1,5	400	7500	300	78	150	41010270

Wymiary [mm]

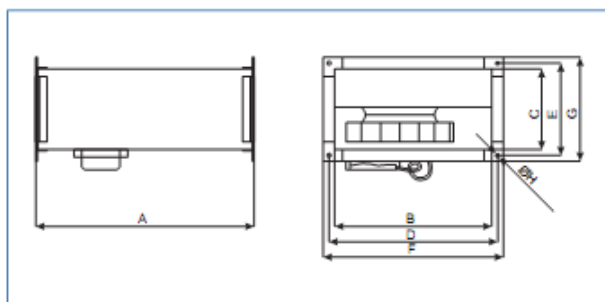

Typ	A	B	C	D	E	F	G	ØH
190	402	298	148	320	170	340	190	9
220	502	398	198	420	220	440	240	9
280	532	498	248	520	270	540	290	9
315	565	500	298	522	320	540	338	9
355	725	600	348	622	370	640	388	9
400	725	600	348	622	370	640	388	9
450	725	700	400	722	422	740	440	9
500	880	800	500	822	522	840	540	9
560	1000	1000	500	1022	522	1040	540	9